

## G-WASH configurations

Washing or Decoating or Developing with loading / unloading station on the same side

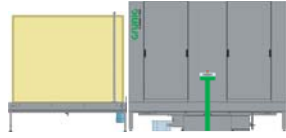

Washing or Decoating or Developing with loading / unloading magazine on the same side

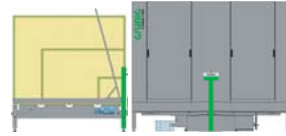

IN-LINE Washing or Decoating or Developing with loading and unloading stations

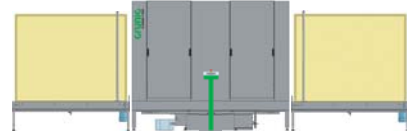

IN-LINE Washing or Decoating or Developing with loading and unloading magazines

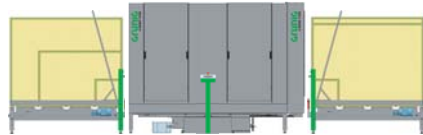

IN-LINE Washing and Decoating with loading and unloading magazines



## G-LINE configurations

Integration of Coating and CtS Equipment

IN-LINE CtS Exposure with loading and unloading magazines

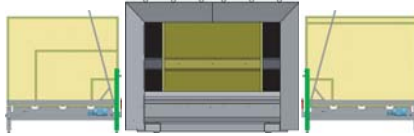

IN-LINE CtS Exposure and Developing with loading and unloading magazines

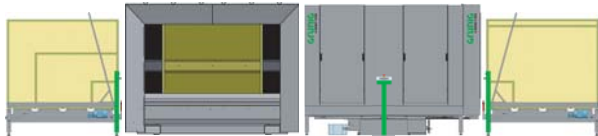

IN-LINE Coating, Drying, CtS Exposure and Developing with loading and unloading magazines

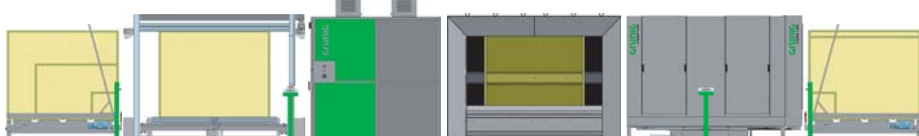

IN-LINE Washing, Decoating, Drying, Coating, Drying, CtS Exposure and Developing with loading and unloading magazines



# MODULAR IN-LINE CONCEPT

# X S

eXcellent Screens



## G-LINE 190XS IN-LINE SCREEN HANDLING SYSTEM

Loading height: 500 mm  
 Size range (Screen width): 1000, 1250, 1500 - 3000 mm (500 mm increment)  
 Size range (Screen height): 1200 - 2000 mm (200 mm increment)

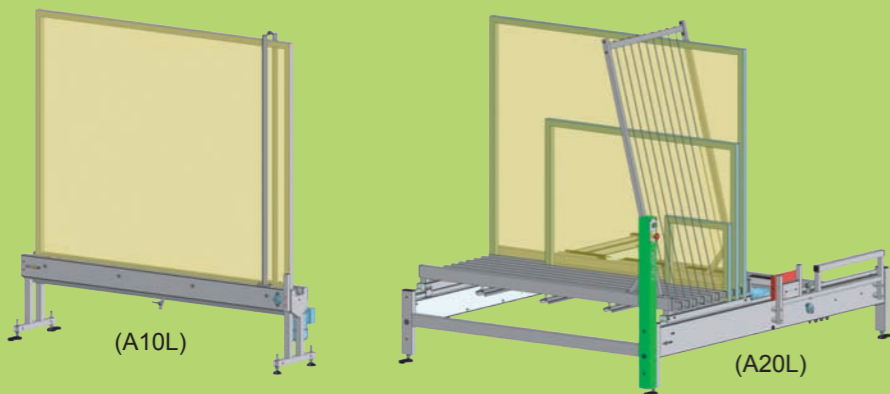

### Single frame handling (1 screen per slot)

- Loading / unloading station (A10L, left hand side / A10R, right hand side)
- Magazine stationary (A20L, left hand side / A20R, right hand side)
- Magazine revolving (A40L, left hand side / A40R, right hand side)

### Multi frame handling (multiple screens per slot)

- Loading / unloading station (A15L, left hand side / A15R, right hand side)
- Magazine stationary (A25L, left hand side / A25R, right hand side)
- Transfer modul (A85L, left hand side / A85R, right hand side)

### Options

- Direction of movement to the left (Option DL)
- Direction of movement to the right (Option DR)

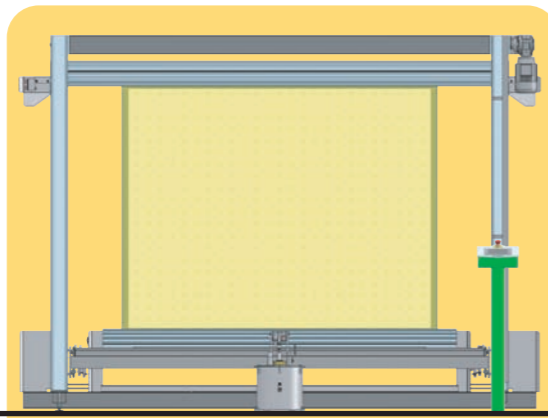
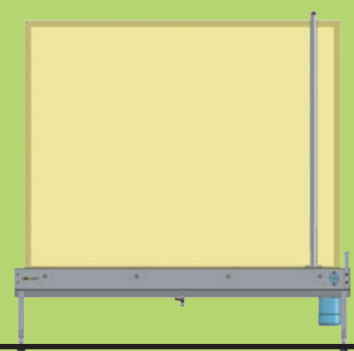

## CtS-INTEGRATION

The G-LINE 190XS will change your CtS Equipment to a full working IN-LINE system.

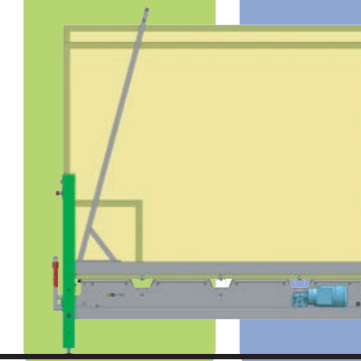
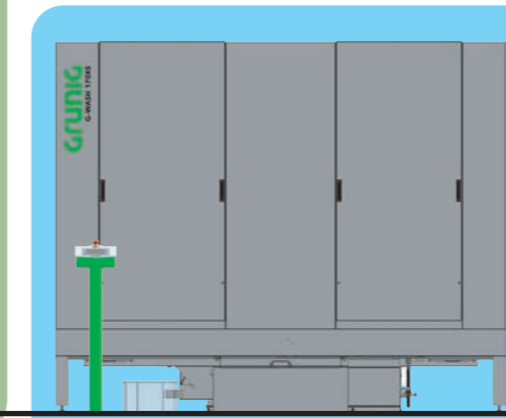
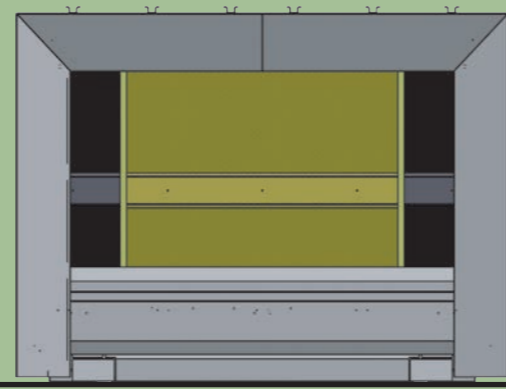

## G-DRY 590XS IN-LINE DRYING SYSTEM

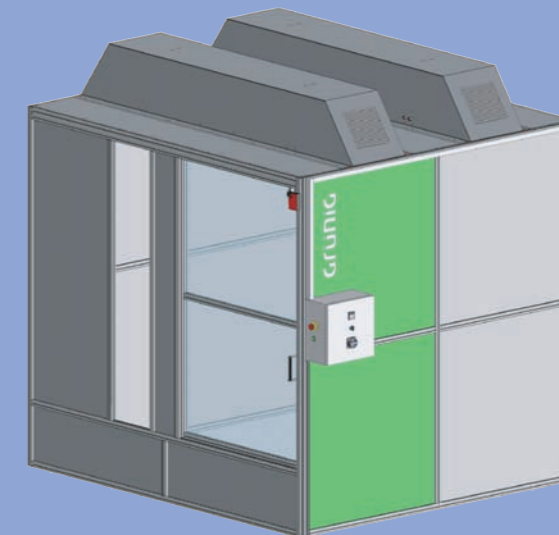

All G-LINE 190XS magazines can be extended with the G-DRY 590XS IN-LINE dryer.

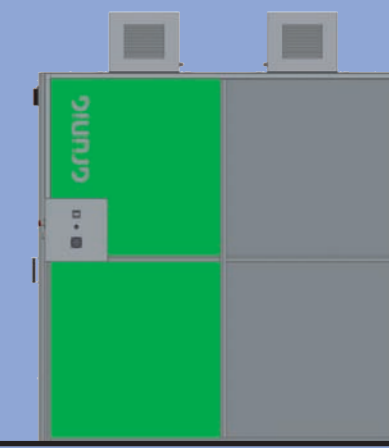

## G-COAT 415 IN-LINE COATING SYSTEM

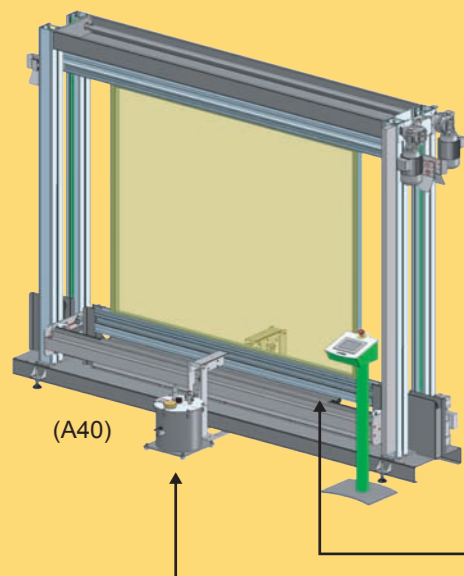

Edge cleaning  
(Option R)

Emulsion refilling  
(Option AF)

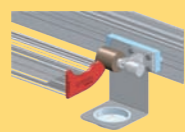

## G-WASH 170XS IN-LINE WASHING SYSTEM

### Blow-off systems

- Blow-off module (A90L, left hand side)
- Blow-off module (A90R, right hand side)

### Nozzle systems

- Washing (A10)
- Decoating (A20)
- Developing (A30)

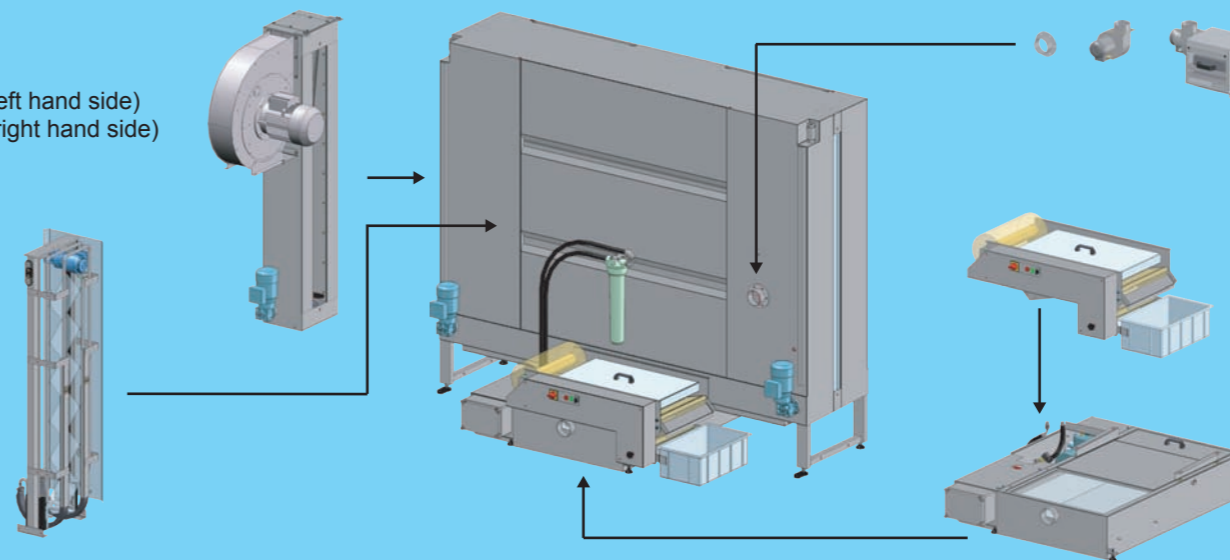

### Exhaust air systems

- Connection tube (Option V1)
- Fan (Option V2)
- Aerosol filter (Option V3)

### G-WASH 040XS

- #### Filter systems
- Coarse filter (Option FG)
  - Inclined filter (Option FS)

### RECYCLEAN

- #### Tank and Pump systems
- Washing (A110, A120)
  - Decoating (A210, A211)
  - Developing (A300, A310, A311)