

G-WASH configurations

Washing or Decoating or Developing with loading / unloading station on the same side

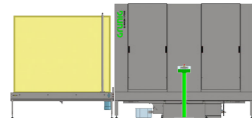

Washing or Decoating or Developing with loading / unloading magazine on the same side

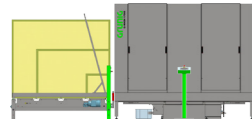

IN-LINE Washing or Decoating or Developing with loading and unloading module

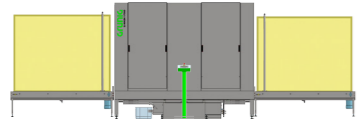

IN-LINE Washing or Decoating or Developing with loading and unloading magazine

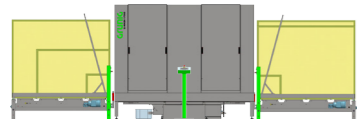

IN-LINE Washing and Decoating with loading and unloading magazine



G-LINE configurations (Integration of Coating and CtS equipment)

IN-LINE CtS Illustration with loading and unloading magazine

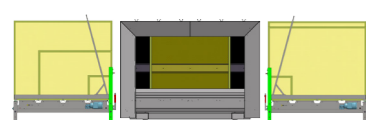

IN-LINE CtS Illustration and Developing with loading and unloading magazine

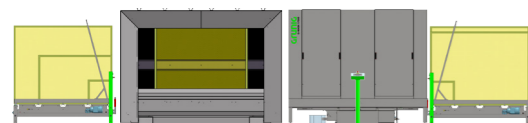

IN-LINE Coating, Drying, CtS Illustration and Developing with loading and unloading magazine

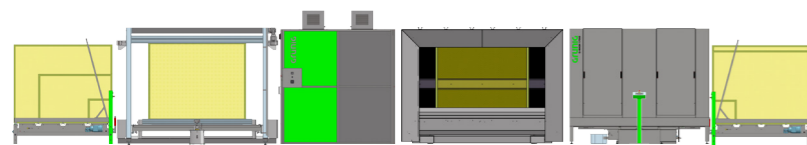

IN-LINE Washing, Decoating, Drying, Coating, Drying, CtS Illustration and Developing with loading and unloading magazine

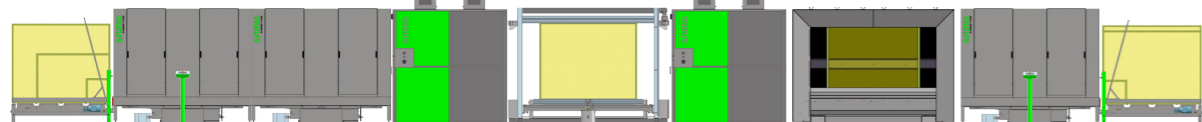

The machine is in compliance with the EU machinery directives (EC conformity)

Technical changes are reserved

All measures in mm

November 14

IN-LINE concept designed for modular extension: G-WASH 170XS for a flexible automation of all the washing processes



G-WASH 170XS

GRÜNIG

Grünig-Interscreen AG
Ringgenmatt 14
CH-3150 Schwarzenburg
Switzerland

Phone +41 31 734 2600
Fax +41 31 734 2601
www.grunig.ch
mail@grunig.ch

GRUNIG G-LINE SYSTEM: Modular IN-LINE CONCEPT

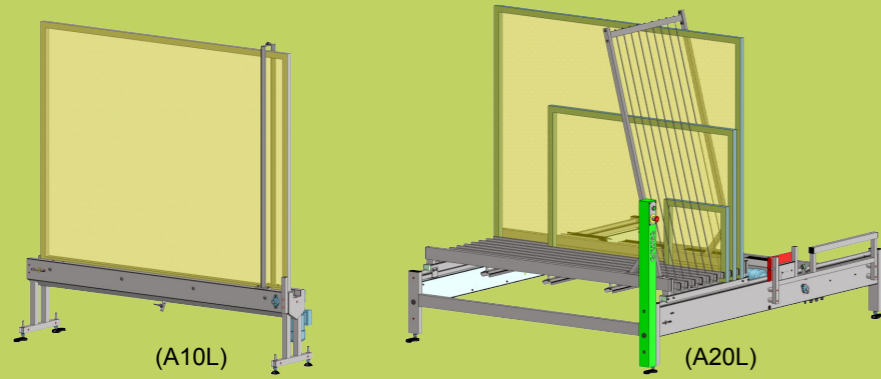

G-LINE 190XS IN-LINE SCREEN HANDLING SYSTEM

Loading height: 500 mm
 Size range (screen width): 1000, 1250, 1500-3000mm (in 500mm increments)
 Size range (screen height): 1200 - 2000 mm (in 200mm increments)

Single frame handling (1 screen per slot position)

- Loading / unloading station (A10L, left-hand side / A10R, right-hand side)
- Stationary magazine (A20L, left-hand side / A20R, right-hand side)
- Stationary magazine with screen lifting (A30L, left-hand side / A30R, right-hand side)
- Revolving magazine (A40L, left-hand side / A40R, right-hand side)

Multi frame handling (several screens per slot position)

- Loading / unloading station (A15L, left-hand side / A15R, right-hand side)
- Stationary magazine (A25L, left hand side / A25R, right hand side)
- Stationary magazine with screen lifting (A35L, left-hand side / A35R, right-hand side)
- Transfer module (A85L, left-hand side / A85R, right-hand side)

Options

- Direction of movement: to the left (Option DL)
- Direction of movement: to the right (Option DR)

CtS-INTEGRATION

The G-LINE 190XS will transform your CtS equipment into a flexible IN-LINE system.

G-DRY 590XS IN-LINE DRYING SYSTEM

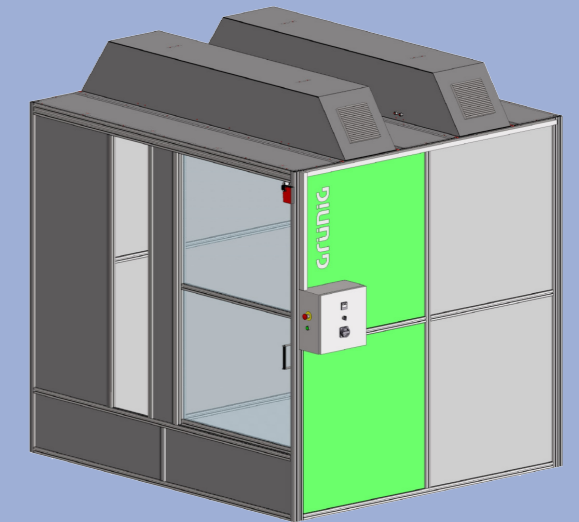

All G-LINE 190XS magazines can be completed by the G-DRY 590XS IN-LINE dryer (T1) or with a protection enclosure (S1).

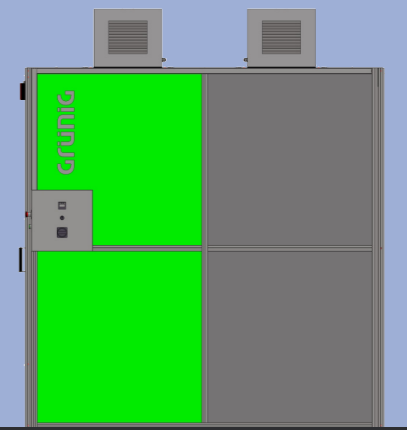
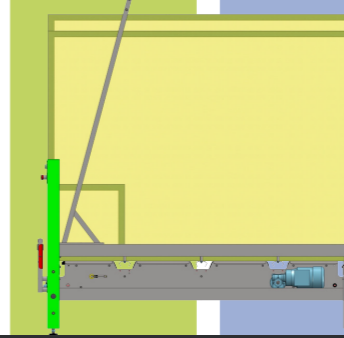
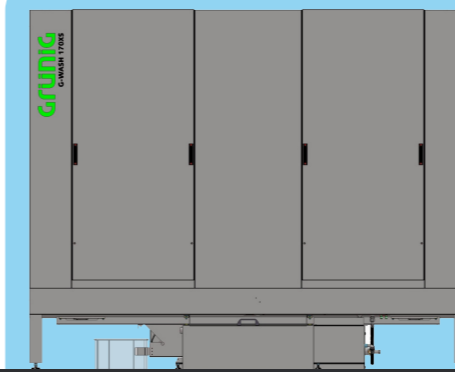
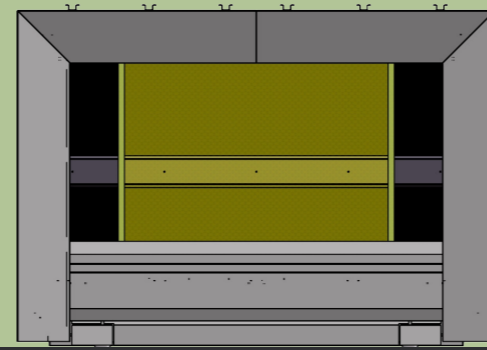
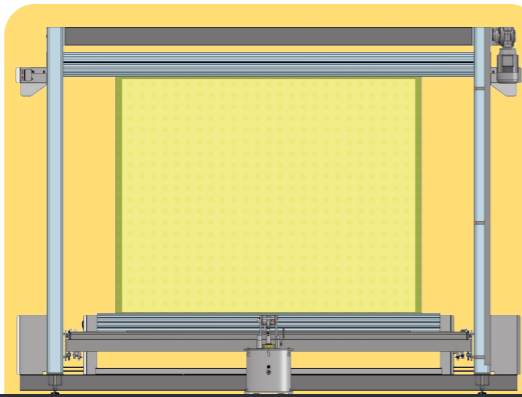
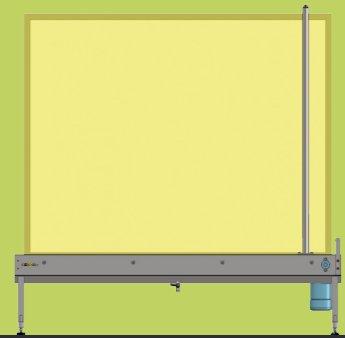

G-COAT 415 IN-LINE COATING-SYSTEM

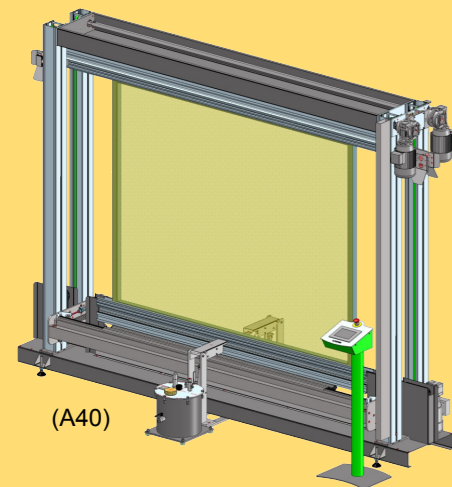

Edge claning
(Option R)

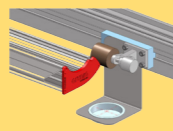

Emulsion
refilling system
(Option AF)



G-WASH 170XS IN-LINE WASHING SYSTEM

Blow-off system

- Blow-off module (A90L, left)
- Blow-off module (A90R, right)

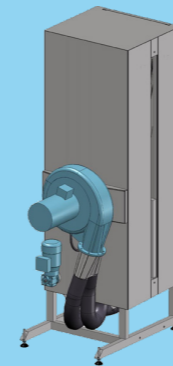

Nozzle systems

- Washing (A10)
- Decoating (A20)
- Developing (A30)

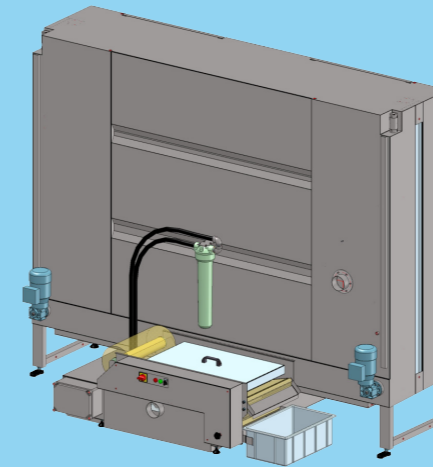

Exhaust air system

- Connection tube (Option V1)
- Ventilator (Option V2)
- Aerosol filter (Option V3)



G-WASH 040XS filter systems

- Coarse filter (Option FG)
- Inclined filter (Option FS)

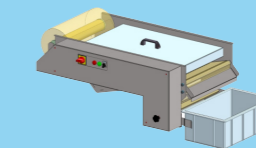

RECYCLEAN

Tank and pump systems

- Washing (A110, A120)
- Decoating (A210, A211)
- Developing (A300, A310, A311, A312)

